

allen + roth

welcoming • sophisticated • inspiring

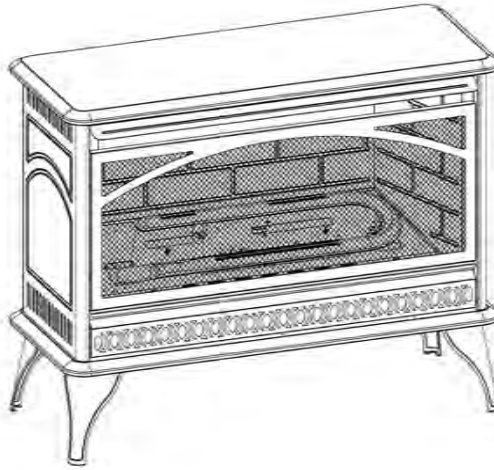

ANS Z21.11.2-2019

ALLEN + ROTH and logo design are trademarks or registered trademarks of LF, LLC. All rights reserved.

ITEM #4976297

## VENT-FREE DUAL FUEL GAS STOVE HEATER

MODEL #ARSTDF26I

**! CAUTION—FOR YOUR SAFETY**

**Español p. 33**

**WARNING:** If the information in this manual is not followed exactly, a fire or explosion may result causing property damage, personal injury, or loss of life.

- Do not store or use gasoline or other flammable vapors and liquids in the vicinity of this or any other appliance.
- **WHAT TO DO IF YOU SMELL GAS:**
  - Do not try to light any appliance.
  - Do not touch any electrical switch; do not use any phone in your building.
  - Immediately call your gas supplier from a neighbor's phone. Follow the gas supplier's instructions.
  - If you cannot reach your gas supplier, call the fire department.
- Installation and service must be performed by a qualified installer, service agency, or the gas supplier.

This is an unvented gas-fired heater. It uses air (oxygen) from the room in which it is installed. Provisions for adequate combustion and ventilation air must be provided. Refer to the **AIR FOR COMBUSTION AND VENTILATION** section on page 8 of this manual.

This appliance may be installed in an aftermarket, permanently located, manufactured (mobile) home, where not prohibited by local codes. This appliance is only for use with propane or natural gas. This appliance is equipped with a simple means to switch between propane and natural gas. Field conversion by any other means including the use of a kit is not permitted.

**INSTALLER:** Leave this manual with the appliance.  
**CONSUMER:** Retain this manual for future reference.

**Questions, problems, missing parts?** Before returning to your retailer, call our customer service department at 888-534-1578, 9 a.m. - 5 p.m., EST, Monday - Friday. You could also contact us at [support@hhdyn.com](mailto:support@hhdyn.com) or visit [www.lowes.com](http://www.lowes.com).

## Table of Contents

Specifications.....	2
Safety Information .....	3
Product Identification.....	6
General Preparation .....	7
Preparing for Installation.....	8
Installation .....	11
Log Placement.....	21
Operation .....	22
Care and Maintenance .....	25
Troubleshooting Guide .....	27
Parts List.....	30
Limited Warranty .....	31

### **▲ WARNING**

**This appliance is equipped for (Natural or Propane) gas. Field conversion is not permitted other than between natural or propane gases.**

## Specifications

**▲ WARNING** Read this entire manual and all operating instructions before operating this heater.

**IMPORTANT:** Read all instructions and warnings carefully before starting installation. Failure to follow these instructions may result in possible injury to persons or a fire hazard and will void the warranty.

Only a qualified installer, service agent, or local gas supplier may install and service this product.

Model #	ARSTDF26I	
Max. Input Rating (BTU/Hr)	25,408	25,068
Min. Input Rating (BTU/Hr)	20,000	15,000
Gas Type	LP/Propane	Natural Gas
Ignition Type	Pizeo	
Manifold Pressure	9 in. W.C.	4 in. W.C.
<b>Inlet Gas Pressure</b>		
Maximum	14 in. W.C.	10,5 in. W.C.
Minimum*	11 in. W.C.	5 in. W.C.

\*For Purpose of Input Adjustment

## Safety Information

### **▲WARNING** FIRE, EXPLOSION, AND ASPHYXIATION HAZARD

**Improper adjustment, alteration, service, maintenance, or installation of this heater or its controls can cause death or serious injury.**

**Read the following instructions and precautions in User's Information Manual provided with this heater.**

**▲WARNING** **CARBON MONOXIDE POISONING:** Early signs of carbon monoxide poisoning resemble the flu with headaches, dizziness, or nausea. If you have these signs, the heater may not be working properly. Get fresh air immediately, and have the heater serviced. Some people are more affected by carbon monoxide than others: pregnant women, people with heart or lung disease, people who are anemic, those under the influence of alcohol, and those living in high altitudes.

**NATURAL AND PROPANE/LP GAS:** Natural and propane/LP gases are odorless. An odor-making agent is added to the gas. The odor helps you detect a gas leak. However, the odor added to the gas can fade. Gas may be present even though no odor exists. Make certain you read and understand all warnings. Keep this manual for reference. It is your guide to operating this heater safely.

**WARNING:** This appliance can be used with propane or natural gas. It is shipped from the factory adjusted for use with propane.

**WARNING: Do not attempt to access or change the setting of the fuel selection means.**

**Access to and adjustment of the fuel selection means must only be performed by a qualified service person when connecting this appliance to a specified fuel supply at the time of installation.**

**Change of the selector setting to other than the fuel type specified at the time of installation could damage this appliance and render it inoperable.**

**The installer shall replace the access cover before completing the installation and operating this appliance.**

### **WARNING:**

- Due to high temperatures, the heater should be located out of traffic and away from furniture and draperies.
- The heater becomes very hot when operating. Children and adults should be alerted to the hazard of high surface temperature and should stay away to avoid burns or clothing ignition. The heater will remain hot for a time after shutoff. Allow surfaces to cool before touching.
- Young children should be carefully supervised when they are in the same room with the appliance.
- Do not place clothing or other flammable material on or near the heater. Never place any objects in the heater.
- Installation and repair should be done by a qualified service person. The heater should be inspected before use and at least annually by a professional service person. More frequent cleaning may be required due to excessive lint from carpeting, bedding material, etc. It is imperative that control compartments, burners, and circulating air passageways of the heater be kept clean.
- This appliance is intended for supplemental heating.

## Safety Information (cont.)

### **WARNING:**

- Any safety screen or guard removed for servicing an appliance must be replaced prior to operating the heater.
- Any change to this heater or its controls can be dangerous.
- Do not use a blower insert, heat exchanger insert or other accessory not approved for use with this heater.
- Keep the heater area clear and free from combustible materials, gasoline, and other flammable vapors and liquids.
- This heater must only be used with the type of gas indicated on the rating label. This heater is not convertible for use with other gases.
- Do not place propane/LP supply tank(s) inside any structure. Place propane/LP supply tank(s) outdoors.
- If you smell gas, do the following:
  - Shut off the gas supply;
  - Do not try to light any appliance;
  - Do not touch any electrical switch, and do not use any phone in your building;
  - Immediately call your gas supplier from a neighbor's phone. Follow the gas supplier's instructions. If you cannot reach your gas supplier, contact the fire department.
- Before using furniture polish, wax, carpet cleaner, or similar products, turn the heater off. If heated, the vapors from these products may create a white powder residue within the burner box or on adjacent walls or furniture.
- This heater must never be installed in a bedroom or bathroom.
- This heater needs fresh air ventilation to run properly and safely. This heater has an Oxygen Depletion Sensing (ODS) safety shutoff system. The ODS shuts down the heater if not enough fresh air is available. See AIR FOR COMBUSTION AND VENTILATION, page 8. If the heater keeps shutting off, see the TROUBLESHOOTING GUIDE, page 27.
- Do not run the heater:
  - Where flammable liquids or vapors are used or stored;
  - Under dusty conditions.
- Do not use this heater to cook food or burn anything.
- Do not use the heater if any part has been under water. Before use, call a qualified service technician to inspect the heater and replace any part of the control system and/or gas control that has been under water.
- Turn off and let the heater cool before servicing. Only a qualified service person should service and repair the heater.
- Operating the heater above elevations of 4,500 feet may cause pilot outage.
- To prevent performance problems, do not use propane/LP fuel tank of less than 100 lb. capacity.
- Provide adequate clearances around air openings.

**CALIFORNIA PROPOSITION 65:** Fuels used in gas-fired heaters and the products of combustion of such fuels contain chemicals known to the state of California to cause cancer, birth defects, or other reproductive harm. This product contains chemicals, including lead and lead compounds, known to the state of California to cause cancer, birth defects, or other reproductive harm. **For more information go to [www.p65Warnings.ca.gov](http://www.p65Warnings.ca.gov)**

## **Safety Information (cont.)**

**QUALIFIED INSTALLING AGENCY:** Only a qualified agency should install and replace gas piping, gas utilization equipment, or accessories, and/or repair and service such equipment. "Qualified agency" means any entity that either in person or through a representative is engaged in and is responsible for:

- Installing, testing, or replacing gas piping; or
- Connecting, installing, testing, repairing, or servicing equipment; is experienced in such work; is familiar with all precautions required; and has complied with all the requirements of the authority having jurisdiction.

### **▲WARNING**

Failure to position the parts in accordance with these diagrams or failure to use only parts specifically approved with this heater may result in property damage or personal injury.

Before beginning assembly or operation of this heater, ensure all parts are present. Check the parts against the package contents list. If any part is missing or damaged, do not attempt to assemble, install, or operate the heater. Contact customer service for replacement parts.

**Estimated Assembly Time:** 1 to 2 hours

### **Tools Required for Assembly (not included, unless otherwise stated):**

Before installing the heater, ensure you have the following:

- Hardware package (included)
- Approved flexible gas hose if allowed by local codes
- Sealant (resistant to natural or propane/LP gas)
- Electric drill with 3/16" drill bit
- Phillips screwdriver
- External regulator (supplied by installer if required)
- Piping (check local codes)
- Equipment shutoff valve
- Test gauge connection
- Sediment trap
- Tee joint
- Pipe wrench
- 3/8" NPT to 3/8" flare fitting

## ***UNPACKING***

1. Remove Stove and Stove Legs from the carton.
2. Remove all protective packaging used on the Stove. Check below the Stove for Stove Leg packaging.
3. Inspect the items for shipping damage. If you notice any damage, contact the dealer where the Stove was purchased.

## Product Identification

**Model:  
ARSTDF26I**

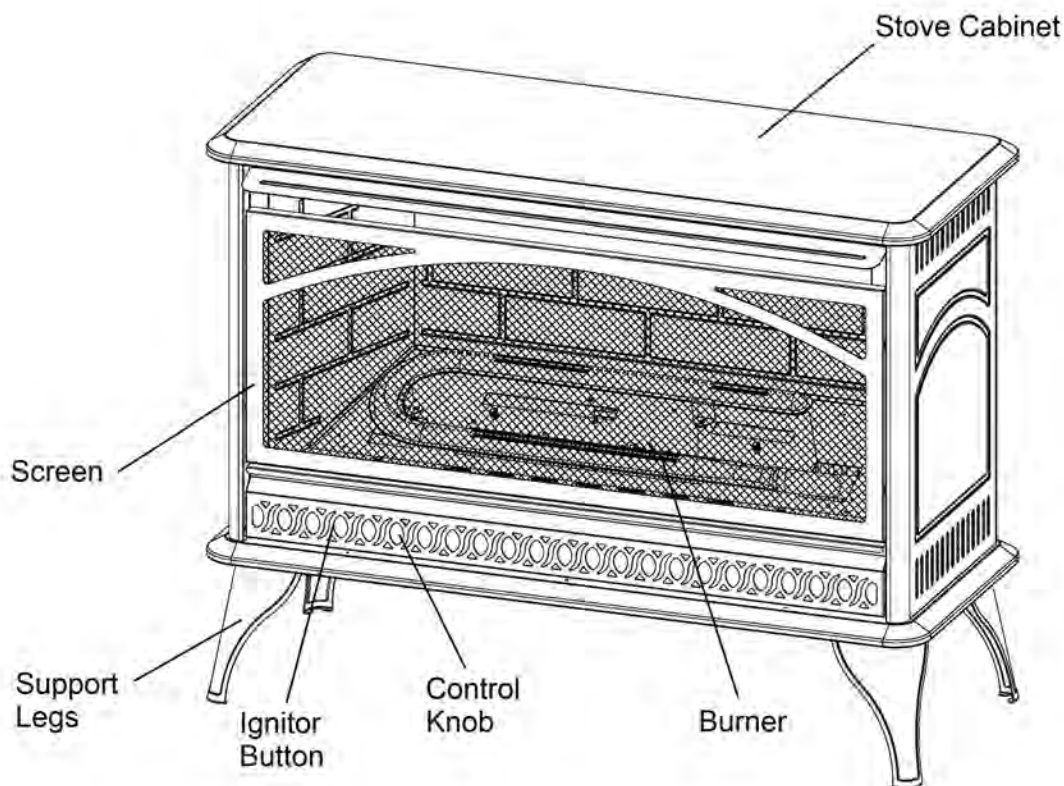

### ***DUAL FUEL CAPABILITY***

The heater is equipped to operate on either propane or natural gas. The heater is shipped from the factory ready for connecting to propane. The heater can easily be changed to natural gas by having your qualified installer follow the instructions on page 17 and the markings on the heater.

### ***SAFETY PILOT***

This heater has an Oxygen Depletion Sensing (ODS) safety shutoff system pilot. The ODS/pilot shuts off the heater if there is not enough fresh air and cuts off the main burner gas in the event of flame out.

### ***LEG KIT***

Four (4) support legs and twelve (12) support leg screws are included with Stove. See page 13.

### ***Optional FAN KIT***

The fan has 3 settings ON/OFF/Auto which helps to distribute the warmed air into the space more rapidly.

**NOTE:** This is an optional accessory and is not required for operation of the heater.



## General Preparation

### **LOCAL CODES**

Install and use the heater with care. Follow all local codes. The installation must conform with local codes or, in the absence of local codes, with the latest edition of *The National Fuel Gas Code, ANS Z223.1/NFPA 54\**.

\*Available from:

American National Standard Institute, Inc.  
1430 Broadway  
New York, NY 10018

National Fire Protection Association, Inc.  
1 Batterymarch Park  
Quincy, MA 02269-9101

This heater is designed for vent-free operation. State and local codes in some areas prohibit the use of vent-free heaters.

**State of Massachusetts:** The installation must be made by a licensed plumber or gas fitter in the Commonwealth of Massachusetts. Sellers of unvented propane or natural gas-fired supplemental room heaters shall provide to each purchaser a copy of 527 CMR 30 upon sale of the unit.

In the State of Massachusetts, unvented propane or natural gas-fired space heaters are prohibited in bedrooms and bathrooms.

**In the State of Massachusetts the gas cock must be a T-handle type. The State of Massachusetts requires that a flexible appliance connector cannot exceed three feet in length.**

The installation of appliances designed for manufactured home (U.S. only) or mobile home installation must conform with the *Standard CAN/CSA Z240 MH, Mobile Housing*, in Canada, or with the *Manufactured Home Construction and Safety Standard, Title 24 CFR, Part 3280*, in the United States, or when such a standard is not applicable, *ANS/NCSBCS A225.1/NFPA 501A, Manufactured Home Installations Standard*.

## **Preparing for Installation**

### **WATER VAPOR IS A BY-PRODUCT OF UNVENTED ROOM HEATERS**

Gas combustion creates water vapor as a by-product. Unvented room heaters create about one (1) ounce (30 ml) of water for every 1,000 BTUs (0.3 kW) of gas input per hour. An unvented room heater is recommended as a supplemental heat source for a single room rather than as a primary heat source for an entire house. The water vapor does not typically create a problem. In most cases, the water vapor enhances the low humidity conditions that are typical of cold weather.

Keep these points in mind so that the water vapor does not create a problem:

- The heater must be the proper size for the application. Provide adequate combustion air and circulation air.
- In humid environments, use a dehumidifier to help lower the amount of water vapor in the air.
- Do not use an unvented room heater as your primary heat source.

### **AIR FOR COMBUSTION AND VENTILATION**

This heater shall not be installed in a room or space unless the required volume of indoor combustion air is provided by the method described in the *National Fuel Gas Code, ANS Z223.1/NFPA 54*, the *International Fuel Gas Code*, or applicable local codes.

### **PRODUCING ADEQUATE VENTILATION**

Spaces in homes can be divided into these ventilation classifications:

- Unusually Tight Construction
- Unconfined Space
- Confined Space

The information on pages 8–10 will help you classify your space and provide adequate ventilation.

#### **Confined and Unconfined Space:**

A confined space has a volume less than 50 cu. ft. per 1,000 BTU/hr (4.8 m<sup>3</sup> per kW) of the total input rating of all appliances installed in that space. An unconfined space has a volume not less than 50 cu. ft. per 1,000 BTU/hr (4.8 m<sup>3</sup> per kW) of the total input rating of all appliances installed in that space. Rooms that are directly connected to the space in which the appliances are installed\*, through openings that do not have doors, are considered a part of the unconfined space.

Do not install this heater in a confined space or unusually tight construction unless you provide provisions for adequate combustion and ventilation air.

\*Adjoining rooms are directly connected only if there are doorless passageways or ventilation grills between them.

#### **Unusually Tight Construction:**

Doors and windows may leak air that provides enough fresh air for combustion and ventilation. However, you must provide additional fresh air in buildings of unusually tight construction. Unusually tight construction is defined as construction that meets the following criteria:

- A. Walls and ceilings exposed to the outside atmosphere have a continuous water vapor retarder with a rating of one perm (6x10<sup>-11</sup> kg per pa-sec-m<sup>2</sup>) or less with openings that are gasketed or sealed.
- B. Doors and windows that can be opened have weather stripping.
- C. Caulking or sealants are applied to areas such as joints around window and door frames; between sole plates and floors; between wall-ceiling joints; between wall panels; at penetrations for plumbing, electrical, and gas lines; and at other openings.

If your residence meets all the above criteria, additional fresh air must be provided. See VENTILATION AIR FROM OUTDOORS on page 10 for more information. If your residence does not meet those three criteria, continue to DETERMINING FRESH-AIR FLOW FOR THE HEATER LOCATION.



## Preparing for Installation (cont.)

### **DETERMINING FRESH-AIR FLOW FOR THE HEATER LOCATION**

#### **Determining if You Have a Confined or Unconfined Space:**

Use the below information to determine if you have a confined or unconfined space. Your space includes the room in which you will install the heater plus any other rooms that are directly connected and have doorless passageways or ventilation grills between the rooms.

1. Determine the volume of the space.  $\text{Length} \times \text{Width} \times \text{Height} = \text{cu. ft. (volume of space)}$ 
  - Example: 20 ft. (length)  $\times$  16 ft. (width)  $\times$  8 ft. (ceiling height) = 2560 cu. ft. (volume of space)  
If additional ventilation to adjoining room(s) is supplied with grills or openings, add the volume of these rooms to the total volume of your space.
2. Divide the space's volume by 50 cu. ft. to determine the maximum BTU/hr the space can support.  
 $\text{_____ (volume of space)} \div 50 \text{ cu. ft.} = \text{(maximum BTU/hr the space can support)}$ 
  - Example: 2560 cu. ft. (volume of space)  $\div$  50 cu. ft. = 51.2 or 51,200 (maximum BTU/hr the space can support)
3. Add the BTU/hr of all fuel burning appliances in the space:  
Example:  
Gas heater \_\_\_\_\_ BTU/hr Gas water heater 40,000 BTU/hr  
Other gas appliances\*+ \_\_\_\_\_ BTU/hr Vent-free heater + 30,000 BTU/hr  
Total = \_\_\_\_\_ BTU/hr Total = 70,000 BTU/hr  

\*Do not include direct-vent gas appliances. Direct-vent appliances draw combustion air from outdoors and vent to the outdoors.
4. Compare the maximum BTU/hr the space can support with the actual amount of BTU/hr used:  
 $\text{_____ BTU/hr (maximum the space can support)}$   
 $\text{_____ BTU/hr (actual amount of BTU/hr used)}$ 
  - Example : 51,200 BTU/hr (maximum the space can support) 70,000 BTU/hr (actual amount of BTU/hr used)  
The space in the above example is a confined space because the actual BTU/hr used is more than the maximum BTU/hr the space can support. You must provide additional fresh air. Your options are as follows:
    - A. Add the space of an adjoining room and rework the above information. If the extra space creates an unconfined space, remove the door to the adjoining room or add ventilation grills between rooms. See VENTILATION AIR FROM INSIDE A BUILDING, page 10.
    - B. Vent the room directly to the outdoors. See VENTILATION AIR FROM OUTDOORS, page 10.
    - C. Install a heater that uses less BTUs/hr if the lower BTUs/hr creates an unconfined space. If the actual BTU/hr used is less than the maximum BTU/hr the space can support, the space is an unconfined space. In this case, no additional fresh air ventilation is needed.

## Preparing for Installation (cont.)

**▲WARNING** If the area in which the heater operates does not meet the required volume for indoor combustion air, you must provide combustion and ventilation air by one of the methods described in the *NATIONAL FUEL GAS CODE, ANS Z223.1/NFPA 54*, the *INTERNATIONAL FUEL GAS CODE*, or applicable local codes.

### VENTILATION AIR FROM INSIDE A BUILDING

Fresh air comes from a connected unconfined space. You must provide two permanent openings when ventilating to a connected unconfined space, one of which that's within 12" of the wall that connects the two spaces (see options 1 and 2, Fig. 1). You may also remove the door into the adjoining room (see option 3, Fig. 1). Follow the *National Fuel Gas Code NFPA 54/ANS Z223.1* for the required size of ventilation grills or ducts.

### VENTILATION AIR FROM OUTDOORS

Extra fresh air is provided via ventilation grills or ducts. You must provide two permanent openings: one within 12" of the ceiling and one within 12" of the floor (see Fig. 2). They must connect directly to the outdoors or spaces that open to the outdoors. Such spaces may include attics or crawl spaces. Follow the *National Fuel Gas Code NFPA 54/ANS Z223.1* for the required size of ventilation grills or ducts.

**IMPORTANT:** Do not provide openings for inlet or outlet air into an attic if the attic has a thermostat-controlled power vent. The power vent will be activated by heated air that enters the attic. You must add the space of the connected unconfined space and rework the information on page 9. The combined spaces must have enough fresh air to supply all appliances in both spaces.

Fig. 1—Ventilation Air from Inside a Building

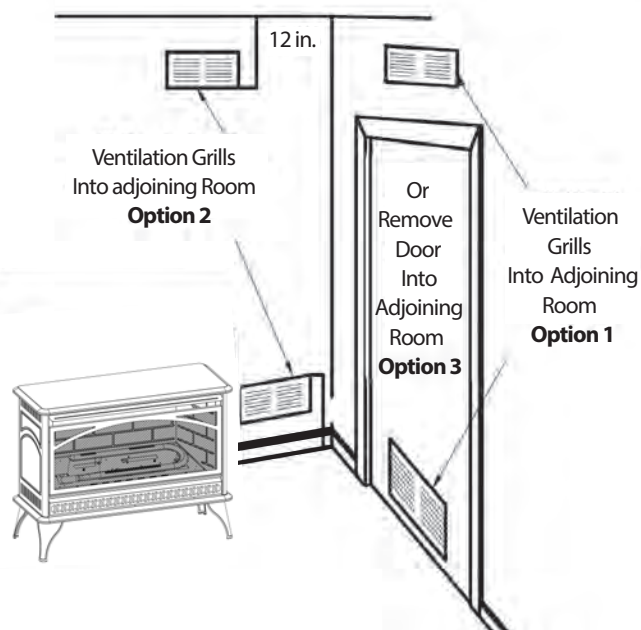
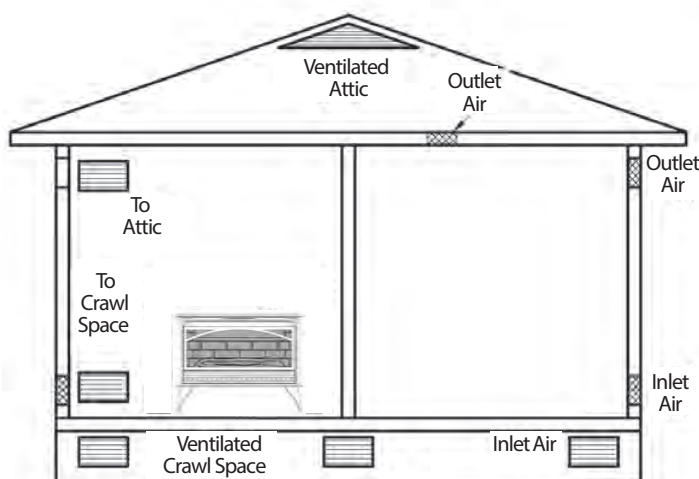

Fig. 2—Ventilation Air from Outdoors



## Installation

**NOTICE:** This heater is intended to be used as a supplemental heating source. Use this heater along with your primary heating system. This heater must not be used as a primary heat source. If you have a central heating system, you may run that system's circulating blower while using this heater. This helps to circulate the heat around your house.

**▲WARNING** A qualified technician must install the heater. Follow all local codes.

**▲WARNING** Never install the heater in a bedroom or bathroom; in a recreational vehicle; where curtains, furniture, clothing, or other flammable objects are less than 36" from the front, top, or sides of the heater; in high traffic areas; or in windy or drafty areas.

**▲CAUTION** This heater creates warm air currents. These currents move heat to wall surfaces that are next to the heater. Installing the heater next to vinyl or cloth wall coverings, or operating the appliance where impurities in the air exist (tobacco smoke, aromatic candles, cleaning fluid, oil or kerosene lamps, etc.), may cause walls to discolor.

**IMPORTANT:** Vent-free heaters add moisture to the air, which is beneficial. However, if this heater is installed in areas without adequate ventilation, mildew may form from too much moisture in the air. See AIR FOR COMBUSTION AND VENTILATION, pages 8 through 10.

**CHECK GAS TYPE:** Be sure your gas supply is right for your heater. If the supply is not correct, do not install the heater. Contact the place where this heater was purchased for a heater appropriate for your gas supply.

**NOTICE:** State or local codes may only allow operation of this appliance in a vented configuration. Check your state or local codes.

## Installation (cont.)

### HEATER CLEARANCES

For convenience and efficiency, install the heater with these points in mind:

- Provide easy access for operation, inspection and service.
- Install the heater in the coldest part of the room.

If this heater is installed directly on carpeting, tile, or other combustible material, other than wood flooring, the heater must be installed on a metal or wood panel that extends the heater's full width and depth.

**▲ CAUTION** If you install the heater in a home garage, a.) ensure the heater pilot and burner are at least 18" above the floor and, b.) locate the heater where moving vehicles will not hit it.

#### **Clearances to Combustibles:**

Carefully follow the instructions below. This stove is designed to set on the floor using the support legs.

**▲ WARNING** Maintain the minimum clearances shown in (see Fig. 3). If you can, provide greater clearances from floor, ceiling and joining wall.

**Fig. 3— Clearances as Viewed from the Front of the Heater (Inches)**

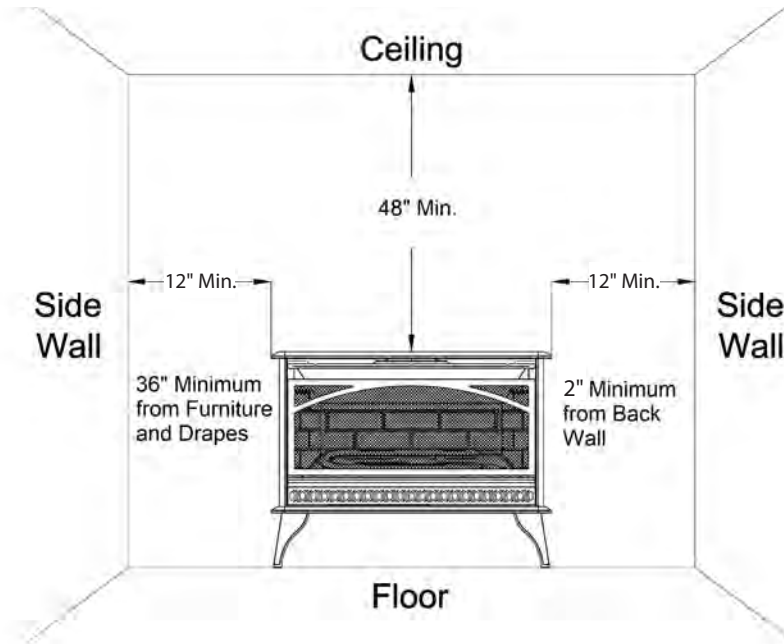

<b>Minimum Clearance to Combustibles</b>				
<b>*Left / Right</b>	<b>Top</b>	<b>Bottom</b>	<b>Front</b>	<b>Rear</b>
12 in.	48 in.	0 in.	36 in.	2 in.
Top clearance is from the top of the heater to the ceiling, wood shelf, or other combustible material.				
Bottom clearance is from the bottom of the heater to the surface of carpet, tile, or other combustible material.				

\*A second side wall must be at least 18 in. away from the other side of the heater. Always maintain a minimum of 36 in. clearance from furniture and draperies.

\*For the installation in residential garages, refer to the CAUTION statement above.

## **Installation (cont.)**

### ***POSITIONING THE HEATER***

This heater sets on the floor by using the Support Legs included. For convenience and efficiency, install the heater as follows:

- In a location with easy access for operation, inspection, and service.
- In the coldest part of the room.
- A minimum of 3' (36") away from furniture and draperies.

### ***FLOOR MOUNTING***

Before installing the Support Legs to the heater base, ensure you have the following items:

- (4) Support Legs
  - (12) Support Leg Screws
1. To prevent scratching, place a blanket on the floor where the heater will be placed for leg installation.
  2. Place the top of the heater on the floor.
  3. Fasten the Support Legs to the heater using the Support Leg Screws (Fig. 4)

**NOTE:** If installing the heater directly on carpeting, tile, or other combustible material, other than wood flooring, the heater must be installed on a metal or wood panel extending the heater's full width and depth.

**Fig. 4—Attaching the Legs**

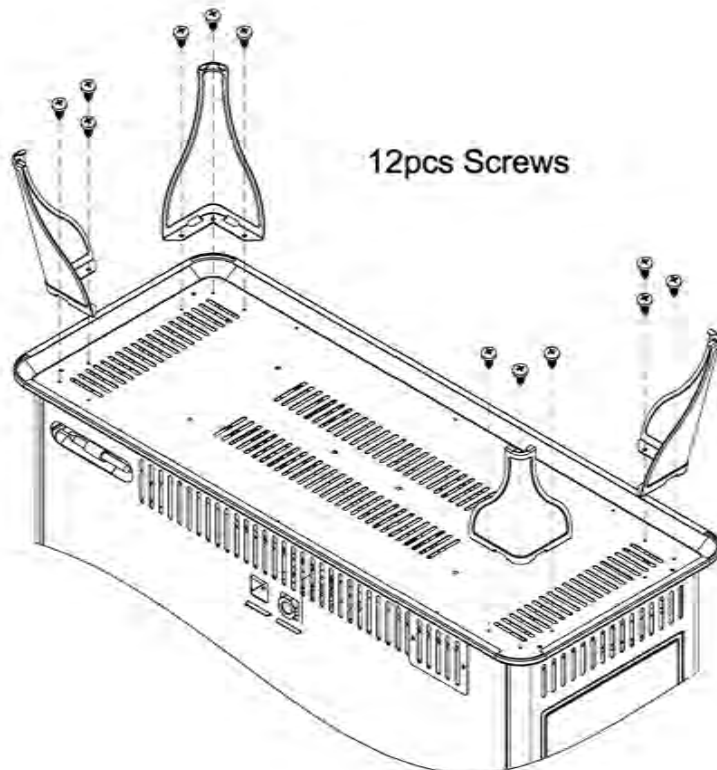

## Installation (cont.)

### INSTALLING THE HHFAN100 BLOWER (OPTIONAL)

**⚠ WARNING** Electrical grounding instructions: This appliance is equipped with a three-prong (grounding) plug for your protection against shock hazard and should be plugged directly into a properly grounded three-prong receptacle (See Fig. 5).

Disconnect heater from the gas supply before installing the fan accessory. Contact a qualified service person to do this.

1. Remove the blower panel using a screwdriver (see Fig. 6).

2. Attach blower duct to the rear panel of the heater using four screws provided (see Fig. 7).

3. Attach blower thermal switch bracket to blower panel with two screws provided. Note the bracket attaches to the upper set of holes (see Fig. 8).

**Fig. 5—Grounded Three-Prong Receptacle**

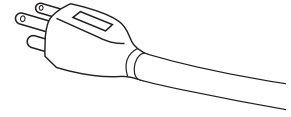

**Fig. 6—Remove Blower Panel**

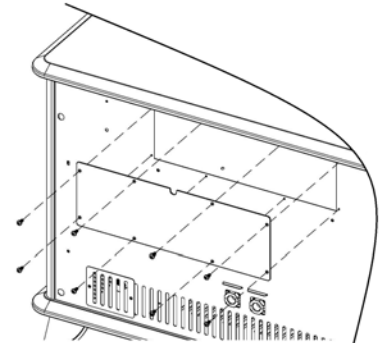

**Fig. 7—Attach Blower Duct**

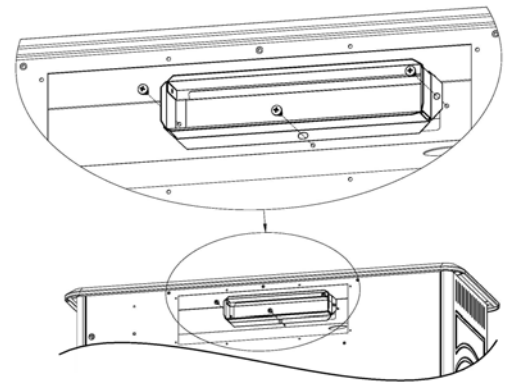

**Fig. 8—Attaching Thermal Switch Bracket**

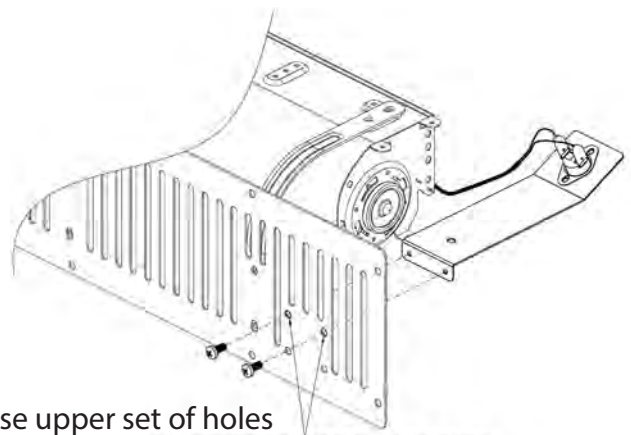

Use upper set of holes



## Installation (cont.)

### INSTALLING THE BLOWER (OPTIONAL) - continued

4. Route wire harness through channel in the back corner of the stove. There are two observation ports on the back of the stove to assist in routing the wire harness. Before securing blower assembly to the stove, put a wire clip on wire harness and snap into the inside of the stove back panel. Secure blower with 8 screws (see Fig. 9).

**Fig. 9—Wire Routing and Blower Attachment**

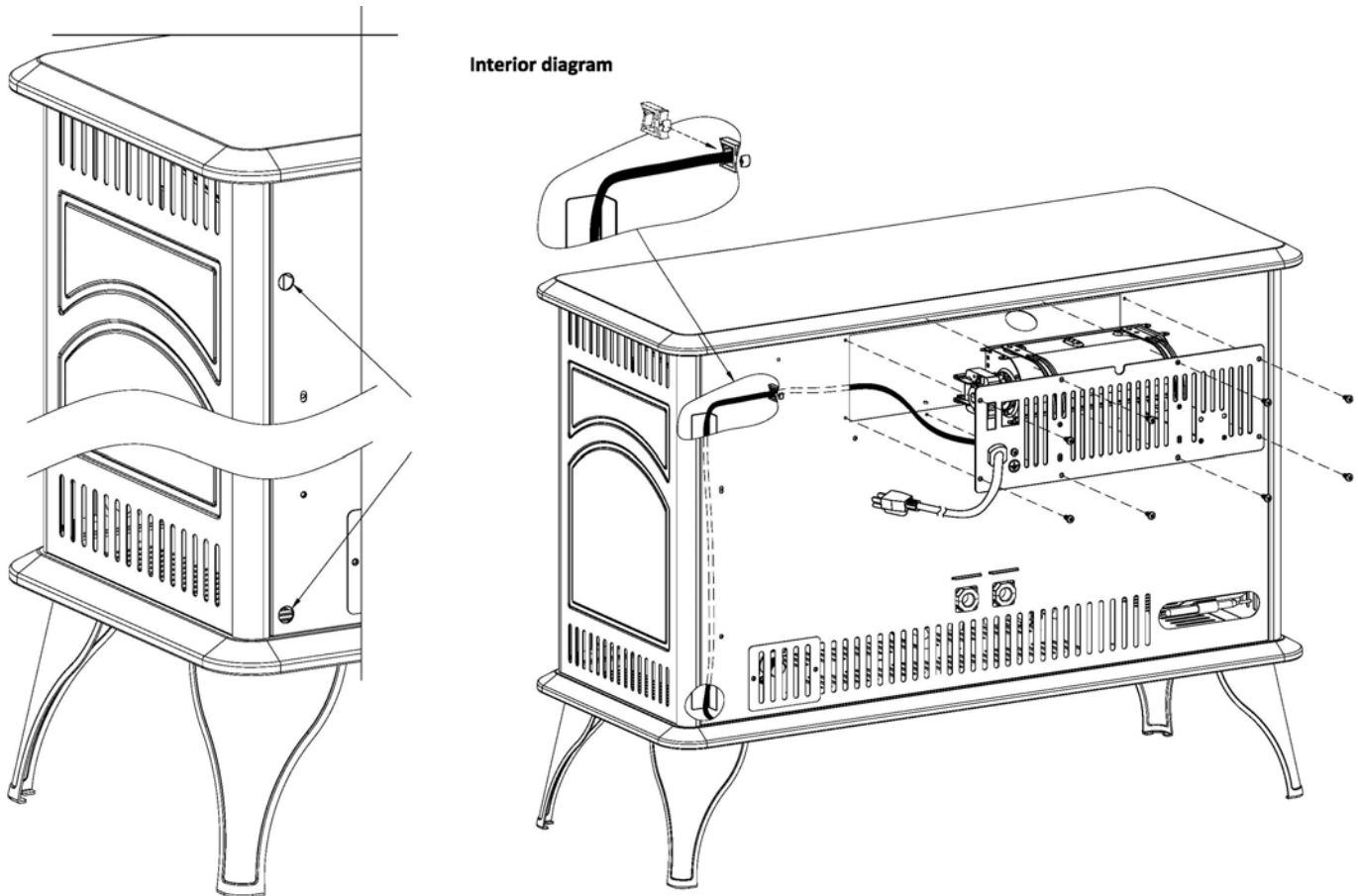

**Fig. 10—Connecting Switch**

5. Route the wire harness as shown through the opening in the control panel. Connect the wires to the switch in the order identified in the wiring diagram (see Fig. 10).

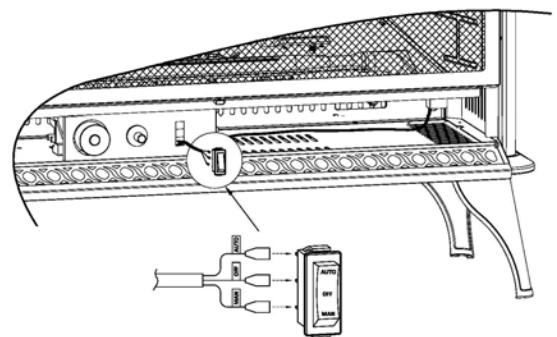

## Installation (cont.)

### **INSTALLING THE BLOWER (OPTIONAL) - continued**

6. Snap Switch into opening in control panel, making sure to position the Auto function on top. Wire clips and a cable tie are provided to help keep the wire harness away from the hot firebox and burner (see Fig. 11)

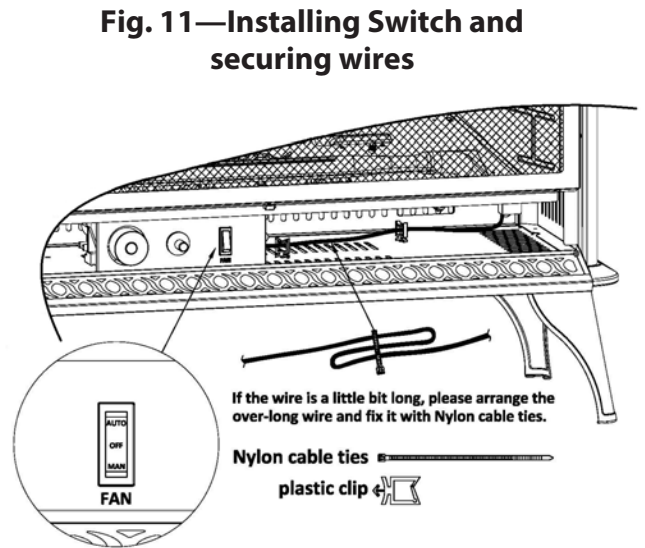

The Blower is equipped with manual ON, OFF and AUTO switch (see Fig. 8). In the Auto position the Blower will automatically come on a few minutes after the burner comes on and will shut off a few minutes after the burner shuts off.

**NOTE:** If any of the original wire supplied with the heater must be replaced, a wire of at least an equal temperature rating must be used. Refer to Fig. 12 for the wiring diagram.

**▲ CAUTION** Label all wires prior to disconnection when servicing controls. Wiring errors can cause improper and dangerous operation. Verify proper operation after servicing.

**Fig. 12—Fan Wiring Diagram**

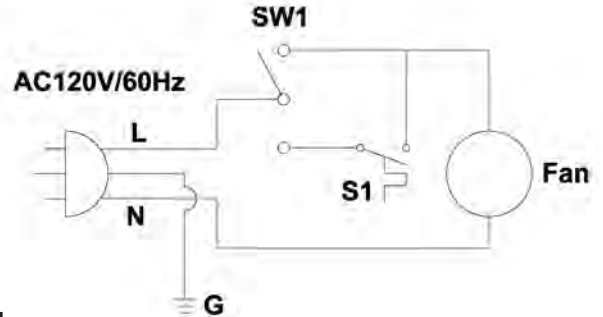

## Installation (cont.)

### **GAS SELECTION INSTRUCTIONS**

**WARNING:** This appliance can be used with propane or natural gas. It is shipped from the factory adjusted for use with propane.

**CAUTION:** The knob to the gas selection means shall not be accessed or adjusted while the appliance is in operation.

**CAUTION:** Two gas line installations at the same time are prohibited. The access plate to simple switching means shall not be opened while heater is in operation.

Installation and adjustments shall be made by a qualified technician only.

NOTE: If you are connecting this appliance to propane do not make any adjustments. Proceed to installing the gas line as instructed in the Owner's Manual.

### **Convert to natural gas:**

Step 1 - Remove access panel

Step 2 - Adjust the gas selector valve

Push in on the selector valve Knob and rotate the knob clockwise until it stops. Release the knob (See Fig. 13)

**Do not operate the appliance between locked positions.**

Step 3 - Replace Access Panel

Reverse step 2 to convert back to propane gas.

**Fig. 13—Gas Selection**

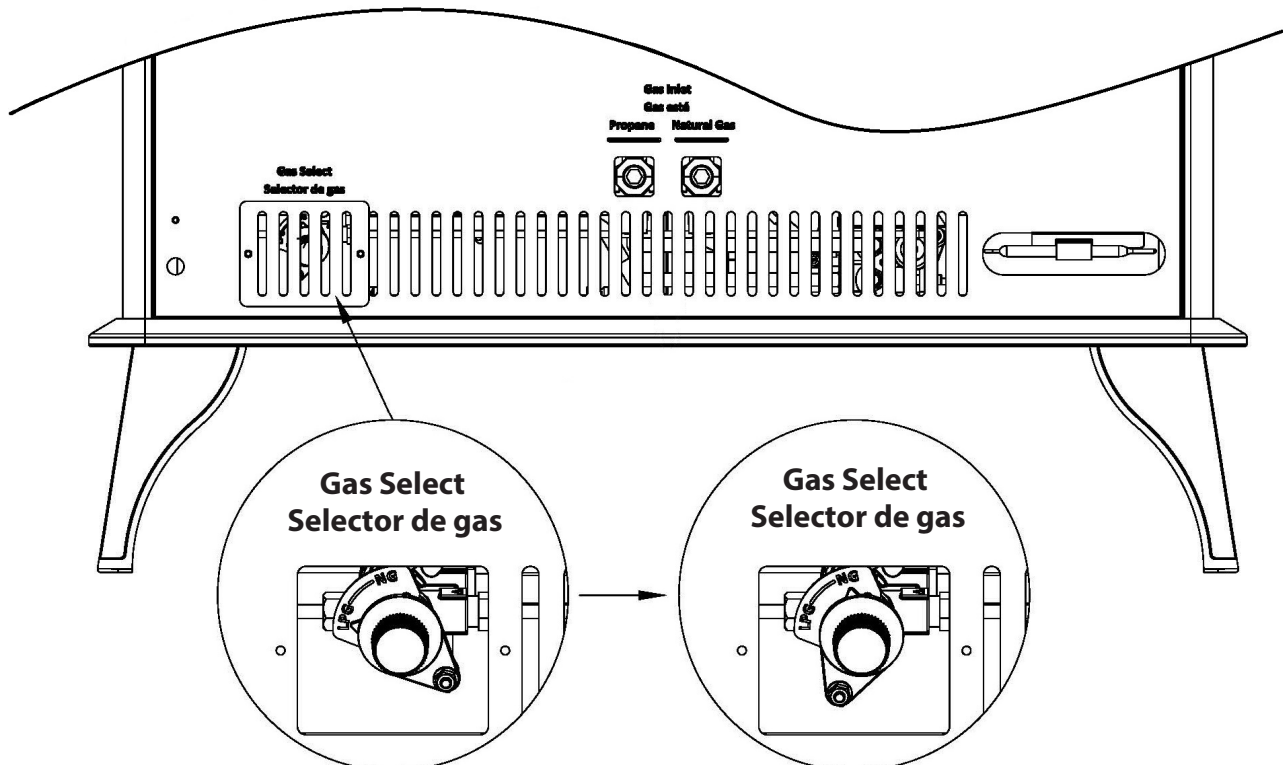

## Installation (cont.)

### CONNECTING TO A GAS SUPPLY

**▲WARNING** A qualified service technician must connect heater to gas supply. Follow all local codes.

**▲WARNING** Never connect the heater to private/non-utility gas wells (commonly known as wellhead gas).

**▲CAUTION** Never connect the heater directly to the gas supply. This heater requires an external regulator (not supplied). The external regulator between the gas supply and heater must be installed. Your gas supplier provides the external regulator for natural gas.

The installer must supply an external regulator for liquid propane. For natural gas, the gas supplier supplies the external regulator. The external regulator reduces incoming gas pressure, and the pressure must be reduced to between 11" and 14" of water column for propane and between 5" and 10.5" of water column for natural gas. Heater regulator damage could occur if the pressure of the incoming gas is not reduced. Install the external regulator with the vent pointing down as shown in Fig. 14. The purpose of pointing the vent down is to protect it from freezing rain or sleet.

**Fig. 14—Regulator Conversion**

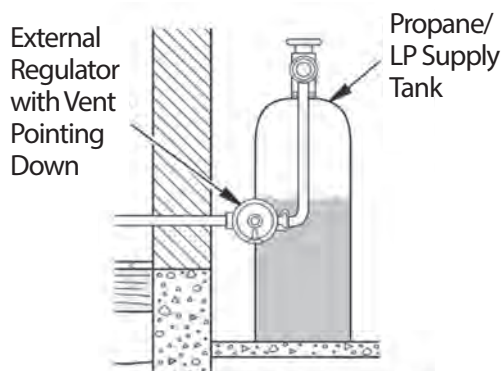

**Fig. 15—Gas Connection**

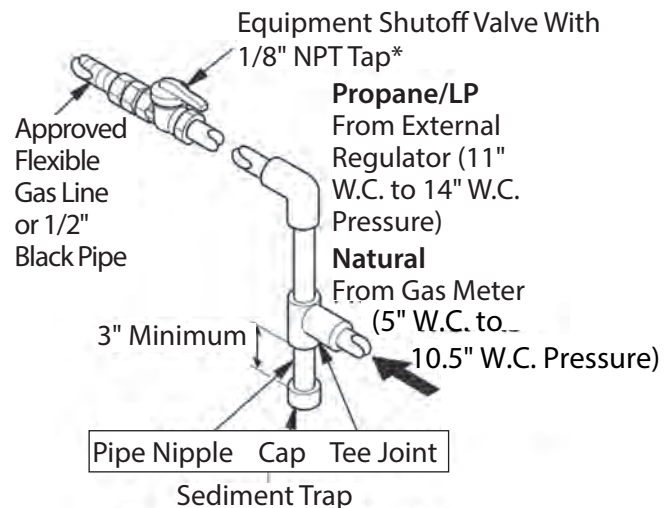

\*The equipment shutoff valve can be purchased from your local home center store.

**▲CAUTION** Use only new black iron or steel pipe. Internally tinned copper tubing may be used in certain areas, depending on your local codes. Use pipe of 1/2" diameter or greater to allow proper volume gas to heater. If the pipe is too small, loss of pressure will occur. Installation must include an equipment shutoff valve, union, and plugged 1/8" NPT tap. The NPT tap must be located within reach for the test gauge hook up and be upstream from heater (see Fig. 15).

**IMPORTANT:** Install equipment shutoff valve in an accessible location. The equipment shutoff valve is for turning on or shutting off the gas to the heater. Apply pipe joint sealant lightly to the male threads. This prevents excess sealant from going into the pipe. The heater valves may become clogged if excess sealant gets into the pipes.

## Installation (cont.)

**▲ CAUTION** Use pipe joint sealant that is resistant to gas (propane or NG). We recommend that you install a sediment trap in a supply line, which traps moisture and contaminants. The sediment trap should be located within reach for cleaning and where it is not likely to freeze. Install it in the piping system between the fuel supply and heater. This keeps contaminants from getting into the heater controls. The heater may not run properly if the sediment trap is not installed or is installed incorrectly.

**▲ CAUTION** Avoid damage to the regulator. Hold the gas regulator with a wrench when connecting into gas piping and/or fittings. NG Models: 6" to 7" W.C. (B-Series) / 5" to 11" W.C. (R-Series). Your gas supplier provides an external regulator for natural gas.

### **INSTALLATION ITEMS NEEDED (NOT PROVIDED):**

- 8" Pipe Wrench
- 8" Adjustable Wrench
- Shutoff Valve
- 3/8" Flexible Gas Line (24" Min.) or 1/2" Black Pipe
- 90 Deg. 3/8 NPT x 3/8" Flare Fitting or 3/8" Street Elbow
- Sealant (Resistant to natural or propane/LP gas)

1. Depending on where your gas supply line is located, a variety of options are possible for routing the gas connection lines. First remove the plug from the regulator for the type of fuel you're using. Install a 3/8" NPT fitting to the heater regulator using sealant. Use of a 90 degree elbow will allow for the minimum clearance to a wall.

**NOTICE:** Most building codes do not permit concealed gas connections. Check your local building code before using a flexible gas line for this installation.

2. Install the gas line to the fitting, and attach it to the shutoff valve (see Fig. 16 & 17).
3. Check all connections for gas leaks.

**Fig. 16—Gas Inlet to Regulator**

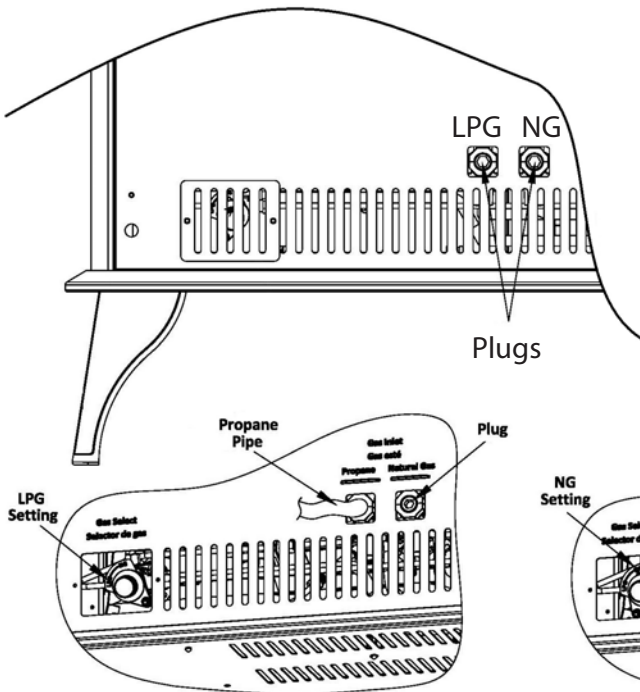

**Fig. 17—Attaching the Flexible Gas Line**

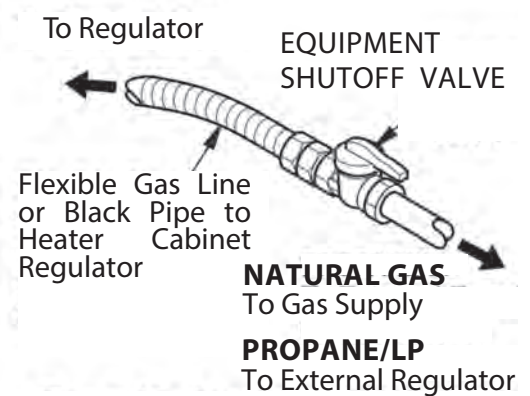



## Installation (cont.)

### CHECKING GAS CONNECTIONS

**▲WARNING** After installing or servicing the heater, test all gas piping and connections for leaks. Immediately correct all leaks.

**▲WARNING** Never use an open flame to check for a leak. Apply a mixture of liquid soap and water to all joints—bubbles may indicate a leak. Immediately correct all leaks.

#### Pressure Testing Gas Supply Piping System

##### Test Pressures in Excess Of 1/2 PSIG (3.5 kPa):

1. Disconnect the heater, including the main gas valve (control valve) and equipment shutoff valve, from the gas supply piping system. Pressures greater than 1/2 PSIG will damage the regulator.
2. Cap off the open end of the gas pipe where the equipment shutoff valve was connected.
3. Open the gas supply tank valve or use compressed air to pressurize the supply piping system.
4. Check all joints of the gas supply piping system. Use a mixture of liquid soap and water in the gas joints to check for leaks—bubbles may indicate a leak.
5. Immediately correct all leaks.
6. Reconnect the heater and equipment shutoff valve to gas supply. Check reconnected fittings or leaks.

##### Test Pressures Equal To or Less Than 1/2 PSIG (3.5 kPa):

1. Close the equipment shutoff valve (see Fig. 18).
2. Open the gas supply tank valve or use compressed air to pressurize the supply piping system.
3. Check all joints from the gas meter to the equipment shutoff valve (see Fig. 18.1 & 18.2).
4. Use a mixture of liquid soap and water in the gas joints to check for leaks—bubbles may indicate a leak.
5. Immediately correct all leaks.

#### Pressure Testing Heater Gas Connections:

1. Open the equipment shutoff valve (see Fig. 18).
2. Open the gas supply tank valve.
3. Ensure the control knob of the heater is in the OFF position.
4. Check all joints from the equipment shutoff valve to the control valve (see Fig. 18.1 & 18.2). Use a mixture of liquid soap and water in the gas joints to check for leaks—bubbles may indicate a leak.
5. Light the heater (see OPERATION, pages 22–23). Check all other internal joints for leaks.
6. Turn off the heater (see TO TURN OFF GAS TO THE HEATER, page 23).

**Fig. 18—Equipment Shutoff Valve**

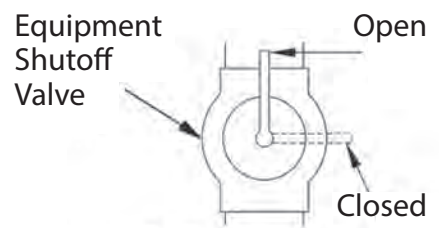

**Fig. 18.1—Checking Gas Joints (Propane/LP Only)**

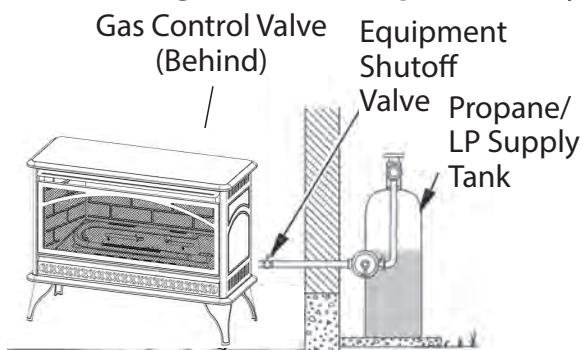

**Fig. 18.2—Checking Gas Joints (Natural Gas Only)**

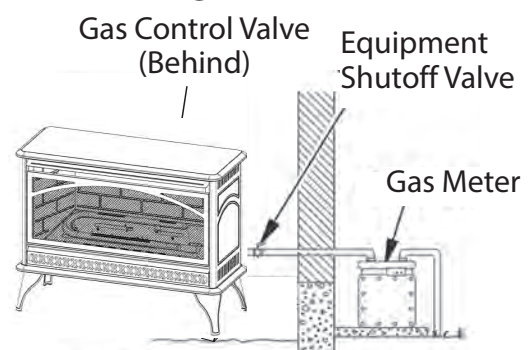



## Log Placement

### ▲ WARNING

Failure to position the parts in accordance with these diagrams or failure to use only parts specifically approved with this heater may result in property damage or personal injury.

### ▲ CAUTION

Check to ensure that no yellow flame comes in contact with any log, both after installation and periodically afterwards. Set the heater to HIGH and check if yellow flames come into contact with any log. If so, reposition the logs as indicated in the below illustrations. Yellow flames coming into contact with logs create unnecessary soot.

Install the logs exactly as indicated (see Fig. 19–20). Do not modify the logs, and use only logs supplied with the heater. The logs are numbered and correspond to the numbers listed below.

### Number of Logs: 5

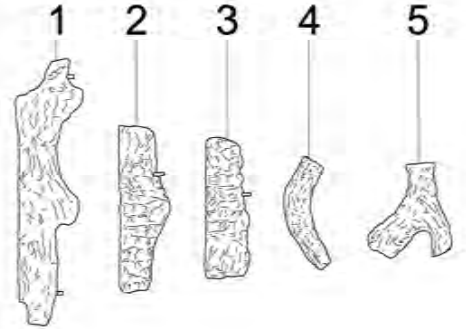
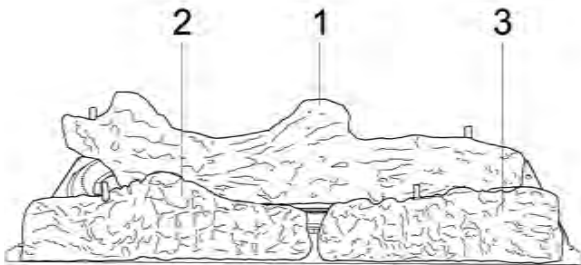
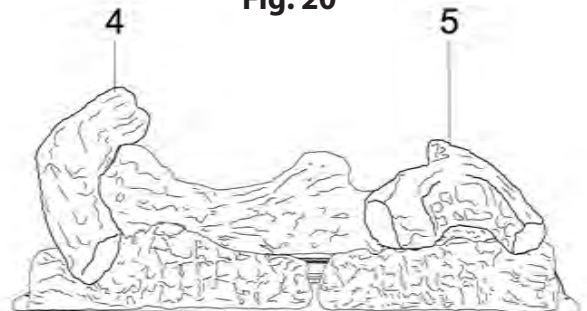

Fig. 19



1. Place log #1 on pins between burners and log #2 and #3 on pins in front of burner.

Fig. 20



2. Place log #4 onto pins in log #1 and #2. Place log #5 onto pins in log #1 and #3.

Fig. 21

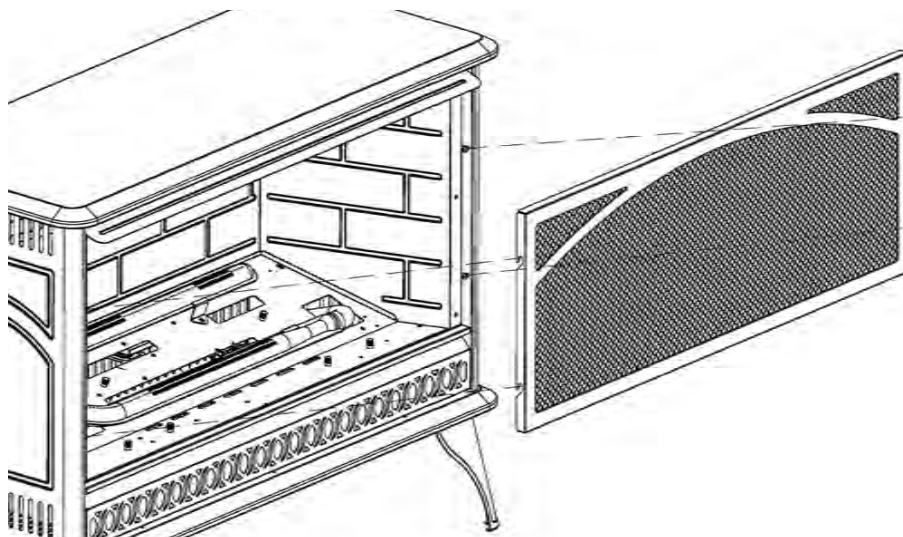

After installing the logs, attach screen by hooking the slots on the ends of the screen on the pins in the side of the stove (see Fig. 21). Note, logs are not shown for clarity.

## Operation

### FOR YOUR SAFETY READ BEFORE LIGHTING



#### **▲ WARNING**

If you do not follow these instructions exactly, a fire or explosion may result causing property damage, personal injury or loss of life.

- A. This appliance has a pilot that must be lighted by the piezo ignitor. When lighting the pilot, follow these instructions exactly.
- B. BEFORE LIGHTING, smell all around the appliance area for gas. Be sure to smell next to the floor because some gas is heavier than air and will settle on the floor.  
  
WHAT TO DO IF YOU SMELL GAS:
  - Do not try to light any appliance.
  - Do not touch any electric switch; do not use any phone in your building.
  - Immediately call your gas supplier from a neighbor's phone. Follow the gas supplier's instructions.
  - If you cannot reach your gas supplier, call the fire department.
- C. Push in or turn the gas control knob using only your hand. Never use tools. If the knob will not push in or turn by hand, do not try to repair it; call a qualified service technician. Force or attempted repair may result in a fire or explosion.
- D. Do not use this room heater if any part has been under water. Immediately call a qualified service technician to inspect the room heater and to replace any part of the control system and any gas control which has been under water.
- E. Any safety screen or guard removed for servicing an appliance must be replaced prior to operating the heater.

## Operation (cont.)

### LIGHTING INSTRUCTIONS

1. **STOP!** Read all the above safety information before proceeding.
2. Open the Lower Access Panel located below the heater screen.
3. Turn the control knob clockwise  to the "OFF" position (see Fig. 22).
4. Wait five (5) minutes to clear out any gas. Then smell for gas, including near the floor. If you smell gas, STOP! Follow "B" in the safety information above. If you don't smell gas, go to the next step.
5. Turn the control knob counterclockwise  to the "PILOT" position.
6. With control knob depressed, push down on the ignitor button until the pilot lights. The pilot is located behind the heater screen centered on the burner (see Fig. 23).

  - Do not attempt to light the pilot by hand.



7. Keep the control knob depressed for (30) seconds after the pilot lights. Then release control knob.
  - If the control knob does not pop up when released, stop and immediately call a qualified service technician or gas supplier.
  - If the pilot goes out, repeat steps 3 through 7. Wait (1) minute before attempting to light pilot again. If after several tries the pilot still goes out, turn the gas control knob clockwise  to the "OFF" position and call a qualified service technician.
8. Turn the control knob counterclockwise  to the desired setting.
9. Close the Lower Access Panel.

Fig. 22 Control Knob

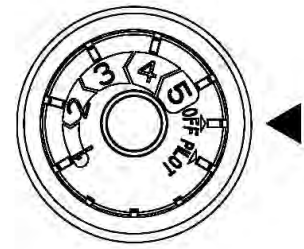
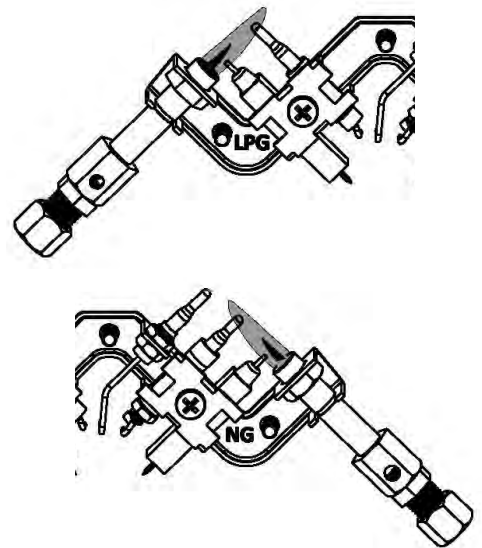

Fig. 23—Pilot



**⚠ WARNING** The stove screen must be in place while the heater is in operation.

### TO TURN OFF GAS TO THE HEATER

1. Turn the control knob clockwise  to the "OFF" position.

#### Shutting Off the Burner Only (Pilot Stays Lit):

1. Turn the control knob clockwise  to the "PILOT" position.

#### THERMOSTATIC CONTROL OPERATION

The thermostatic control valve on this heater operates like a standard thermostat and turns the burner on and off. The thermostat sensing bulb on the control valve used on this heater senses changes in room temperature, and the burner will shut off completely when the room temperature reaches the set temperature. When the room temperature drops below the set temperature, the burner will cycle back on. The control knob can be set to the desired comfort level between 1 and 5.

## Operation (cont.)

### **INSPECTING BURNERS**

Check the pilot flame pattern and burner flame patterns often.

### **PILOT FLAME PATTERN**

Figure 24 shows a correct pilot flame pattern. Figure 25 shows an incorrect pilot flame pattern. The incorrect pilot flame is not touching the thermocouple. This will cause the thermocouple to cool. When the thermocouple cools, the heater will shut down. If pilot flame pattern is incorrect, as shown in Figure 25:

- Turn the heater off (see TO TURN OFF GAS TO THE HEATER, page 23).
- See the TROUBLESHOOTING GUIDE, page 27.

**Fig. 24—Correct Pilot Flame Pattern**  
**Propane Pilot**

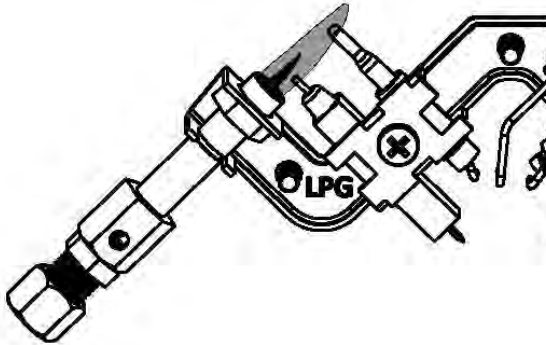

**Fig. 25—Incorrect Pilot Flame Pattern**  
**Propane Pilot**

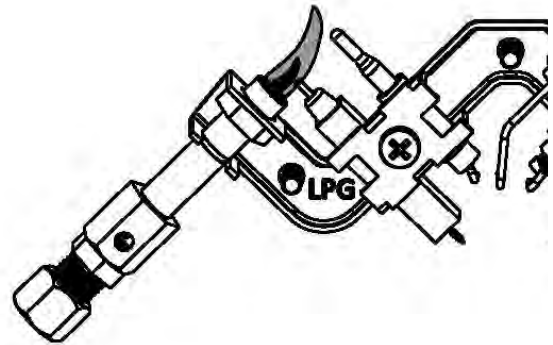

**Natural Pilot**

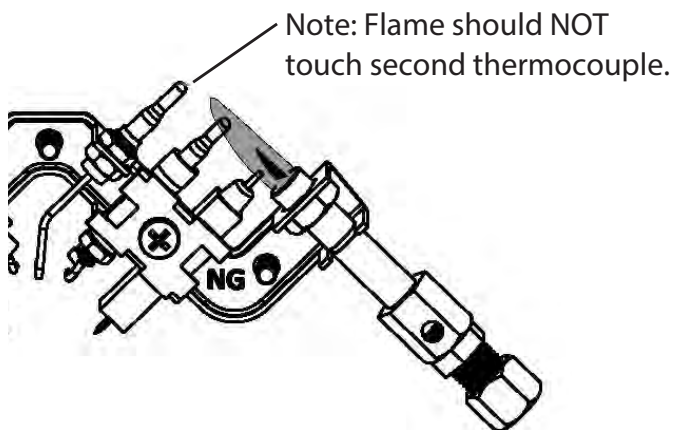

**Natural Pilot**

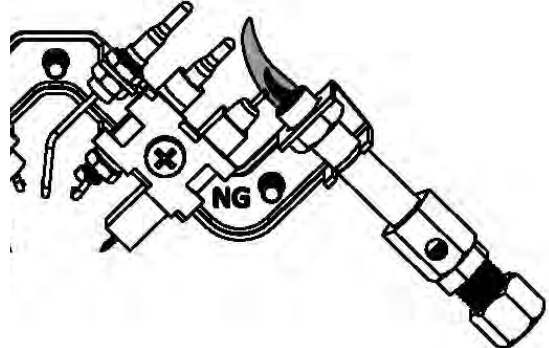

### **⚠ WARNING**

Do not allow fans to blow directly into the heater. Avoid any drafts that alter burner flame patterns.

## Care and Maintenance

### BURNER FLAME PATTERN

Figure 26 shows a correct burner flame pattern. Figure 27 shows an incorrect burner flame pattern. The incorrect burner flame pattern shows sporadic, irregular flame tipping. The flame should not be dark or have an orange/reddish tinge. **NOTE:** When using the heater the first time, the flame will be orange for approximately one hour. If the burner flame pattern is incorrect, as shown in Figure 27, do the following:

- Turn the heater off (see TO TURN OFF GAS TO THE HEATER, page 23).
- See the TROUBLESHOOTING GUIDE, page 27.

Fig. 26—Correct Burner Flame Pattern

Fig. 27—Incorrect Burner Flame Pattern

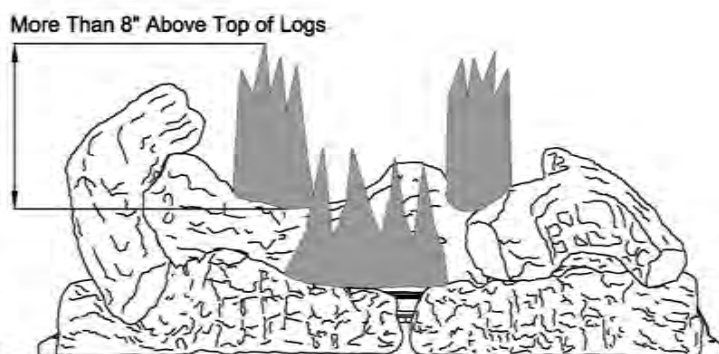
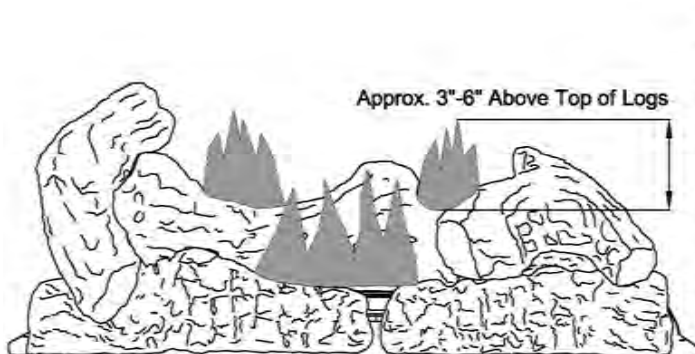

**▲ WARNING** Turn off the heater and let cool before servicing.

**▲ WARNING** Failure to keep the primary air opening(s) of the burner(s) clean may result in sooting and property damage.

**▲ CAUTION** You must keep the control areas, burner, and circulating air passageways of the heater clean. Inspect these areas before using the heater. Have a qualified service person inspect the heater every year. Excessive lint from carpeting, bedding material, pet hair, etc. may require that the heater be cleaned more frequently.

### BURNER ORIFICE HOLDER AND PILOT AIR INLET HOLE

The primary air inlet holes allow the right amount of air to mix with the gas, which creates a clean burning flame. Keep these holes clear of lint, dirt, dust, pet hair, and other debris. Before every heating season, clean these holes—blocked air holes create soot. During operation, the heater should be cleaned at least every three (3) months. A qualified service person should inspect the heater yearly.

Keep the burner tube and pilot assembly clean and free of dirt and other debris. Use compressed air of 30 PSI or less to clean these parts. If using compressed air in a can, follow the directions on the can exactly. You may damage the pilot assembly if the directions are not followed exactly.



## Care and Maintenance (cont.)

1. Shut off the heater, including the pilot. Allow the heater to cool for at least 30 minutes.
2. Inspect the burner, pilot, and primary air inlet holes on the orifice holder for dirt and debris (see Fig. 28).
3. Blow air through the ports/slots and holes in the burner.
4. Check the orifice holder again, which is located at the end of the burner tube. With a cloth or vacuum cleaner nozzle, remove any large particles of dust, dirt, or other debris.
5. Blow air into the primary air holes on the orifice holder.
6. Repeat steps 3 and 4. Clumps of dust/debris may have been pushed into the burner.

Clean the pilot assembly. A yellow tip on the pilot flame indicates dust and dirt in the pilot assembly. A small pilot air inlet hole is about 2" from where the pilot flame comes out of the pilot assembly (see Fig. 29). Ensure the heater is off, and lightly blow air through the air inlet hole. If you do not have compressed air, blowing through a drinking straw will also work.

**Fig. 28—Primary Air Inlet on Heater**

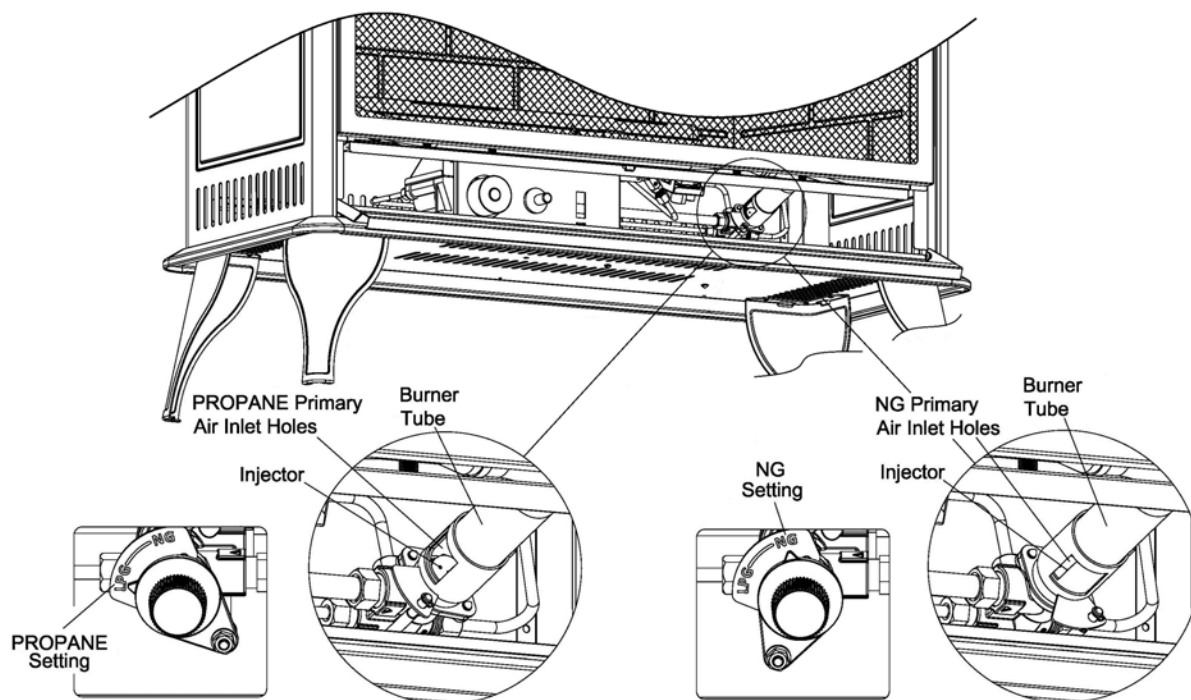

**Fig. 29—Pilot Air Inlet Hole**

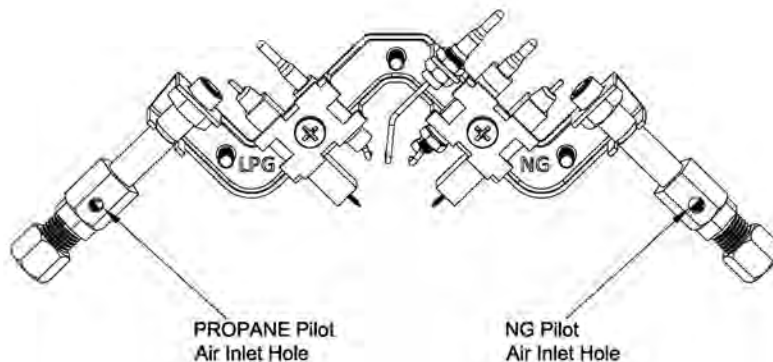

Verify proper operation after servicing.



## Troubleshooting Guide

**▲ WARNING** If you smell gas, do the following:

- Shut off gas supply .
- Do not try to light any appliance.
- Do not touch any electrical switch; do not use any phone in your building.
- Immediately call your gas supplier from a neighbor's phone . Follow the gas supplier's instructions.
- If you cannot reach your gas supplier, call the fire department.

**▲ WARNING** Turn off and let the heater cool before servicing. Only a qualified service person should service and repair the heater.

**▲ CAUTION** Never use a wire, needle, or similar object to clean ODS/pilot. This can damage ODS/ pilot unit.

**IMPORTANT:** Impurities in the air may create odors when operating the appliance. For example, cleaning supplies, paint, cigarette smoke, glues, new carpets, etc. create fumes, which may mix with combustion air and create odors.

Problem	Possible Cause	Solution
There is no spark at the ODS/pilot when the ignitor button is pressed.	<ol style="list-style-type: none"> <li>1. Ignitor electrode is positioned wrong.</li> <li>2. Ignitor electrode is broken.</li> <li>3. Ignitor electrode is not connected to ignitor cable.</li> <li>4. Ignitor cable is pinched or wet.</li> <li>5. Damaged ignitor cable.</li> <li>6. Bad piezo ignitor.</li> </ol>	<ol style="list-style-type: none"> <li>1. Replace electrode.</li> <li>2. Replace electrode.</li> <li>3. Replace ignitor cable</li> <li>4. Free the ignitor cable if it's pinched by any metal or tubing. Keep ignitor cable dry.</li> <li>5. Replace ignitor cable.</li> <li>6. Replace piezo ignitor.</li> </ol>
When the ignitor button is pressed, there is a spark at the ODS/pilot but no ignition.	<ol style="list-style-type: none"> <li>1. Gas supply is turned off or equipment shutoff valve is closed.</li> <li>2. Control knob is not fully pressed in while pressing ignitor button.</li> <li>3. Air in gas lines when installed.</li> <li>4. ODS/pilot is clogged.</li> <li>5. Gas regulator setting is incorrect.</li> <li>6. Control knob not in PILOT position.</li> <li>7. Depleted gas supply (propane).</li> </ol>	<ol style="list-style-type: none"> <li>1. Turn on the gas supply or the open equipment shutoff valve.</li> <li>2. Fully press in the control knob while pressing the ignitor button.</li> <li>3. Continue holding down the control knob. Repeat igniting operation until air is removed.</li> <li>4. Clean ODS/pilot (see CARE AND MAINTENANCE, pages 25 &amp; 26) or replace ODS/pilot assembly.</li> <li>5. Replace gas regulator.</li> <li>6. Turn control knob to PILOT position.</li> <li>7. Contact local propane/LP gas company.</li> </ol>

## Troubleshooting Guide (cont.)

<b>Problem</b>	<b>Possible Cause</b>	<b>Solution</b>
ODS/pilot lights but flame goes out when the control knob is released.	<ol style="list-style-type: none"> <li>1. Control knob is not fully pressed in.</li> <li>2. Control knob is not pressed in long enough.</li> <li>3. Equipment shutoff valve is not fully open.</li> <li>4. Thermocouple connection is loose.</li> <li>5. Thermocouple damaged.</li> <li>6. Control valve damaged.</li> </ol>	<ol style="list-style-type: none"> <li>1. Press in control knob fully.</li> <li>2. After ODS/pilot lights, keep control knob pressed in 30 seconds.</li> <li>3. Fully open equipment shutoff valve.</li> <li>4. Hand tighten until snug, and then tighten ¼ turn more.</li> <li>5. Replace thermocouple.</li> <li>6. Contact customer service.</li> </ol>
Burner(s) does not light after ODS/pilot is lit.	<ol style="list-style-type: none"> <li>1. Burner orifice is clogged.</li> <li>2. Burner orifice diameter is too small.</li> <li>3. Inlet gas pressure is too low.</li> </ol>	<ol style="list-style-type: none"> <li>1. Clean burner orifice (see CARE AND MAINTENANCE, pages 25 &amp; 26) or contact customer service.</li> <li>2. Contact customer service.</li> <li>3. Contact your gas supplier.</li> </ol>
Burner does not light after ODS/pilot is lit. (Heater is set up for natural gas.)	<ol style="list-style-type: none"> <li>1. Inlet gas pressure is too high.</li> </ol>	<ol style="list-style-type: none"> <li>1. Contact your gas supplier.</li> </ol>
There is delayed ignition of the burner(s).	<ol style="list-style-type: none"> <li>1. Manifold pressure is too low.</li> <li>2. Burner orifice is clogged.</li> </ol>	<ol style="list-style-type: none"> <li>1. Contact your gas supplier.</li> <li>2. Clean burner (see CARE AND MAINTENANCE, pages 25 &amp; 26) or contact customer service.</li> </ol>
The burner is backfiring during combustion.	<ol style="list-style-type: none"> <li>1. Burner orifice is clogged or damaged.</li> <li>2. Burner is damaged.</li> <li>3. Gas regulator is damaged.</li> </ol>	<ol style="list-style-type: none"> <li>1. Clean burner orifice (see CARE AND MAINTENANCE, pages 25 &amp; 26 or contact customer service).</li> <li>2. Contact dealer or customer service.</li> <li>3. Replace gas regulator.</li> </ol>
There is a high yellow flame during burner combustion.	<ol style="list-style-type: none"> <li>1. There is not enough air.</li> <li>2. Gas regulator is defective.</li> <li>3. Inlet gas pressure is too low.</li> </ol>	<ol style="list-style-type: none"> <li>1. Check burner for dirt and debris. If found, clean burner (see CARE AND MAINTENANCE, page 25 &amp; 26).</li> <li>2. Replace gas regulator.</li> <li>3. Contact your gas supplier.</li> </ol>
A gas odor is present during combustion.	<ol style="list-style-type: none"> <li>1. Foreign matter between control valve and burner.</li> <li>2. Gas leak—see WARNING Statement at top of page 27</li> </ol>	<ol style="list-style-type: none"> <li>1. Take apart gas tubing and remove foreign matter.</li> <li>2. Locate and correct all leaks (see CHECKING GAS CONNECTIONS, page 20).</li> </ol>
Heater produces a clicking/ticking noise just after burner is lit or shut off.	<ol style="list-style-type: none"> <li>1. Metal is expanding while heating or contracting while cooling.</li> </ol>	<ol style="list-style-type: none"> <li>1. This is common with most heaters. If noise is excessive, contact a qualified service technician.</li> </ol>

## Troubleshooting Guide (cont.)

<b>Problem</b>	<b>Possible Cause</b>	<b>Solution</b>
White powder residue is forming within burner box or on adjacent walls or furniture.	1. When heated, the vapors from furniture polish, wax, carpet cleaners, etc. turn into white powder residue.	1. Turn heater off when using furniture polish, wax, carpet cleaner or similar products.
Heater produces unwanted odors.	1. Heater is burning vapors from paint, hair spray, glues, etc. See IMPORTANT statement, page 27. 2. Gas leak—see WARNING Statement at the top of page 27. 3. The fuel supply is low.	1. Ventilate room. Stop using odor causing products while heater is running. 2. Locate and correct all leaks (see CHECKING GAS CONNECTIONS, page 20). 3. Refill supply tank (Propane /LP models).
Heater shuts off in use (ODS operates).	1. Not enough fresh air is available. 2. The line pressure is low. 3. ODS/pilot is partially clogged.	1. Open window and/or door for ventilation. 2. Contact local gas supplier. 3. Clean ODS/pilot (see CARE AND MAINTENANCE, page 25 & 26)
Gas odor exists even when control knob is in OFF position.	1. Gas leak—see WARNING Statement at top of page 27. 2. Control valve is defective.	1. Locate and correct all leaks (see CHECKING GAS CONNECTIONS, page 20). 2. Contact customer service.
Moisture/condensation is present on windows.	1. Not enough combustion/ventilation air is provided.	1. Refer to AIR FOR COMBUSTION AND VENTILATION requirements, pages 8–10.
There is slight smoke or odor during initial operation.	1. Residues from manufacturing process are present.	1. Problem will stop after a few hours of operation.
Heater produces a whistling noise when burner is lit.	1. Turning control knob to high position when burner is cold. 2. There is air in the gas line. 3. Air passageways on heater are blocked. 4. Burner orifice are dirty or partially clogged.	1. Turn control knob to low position and let it warm up for a minute. 2. Operate burner until air is removed from line. Have gas line checked by local propane/LP gas company. 3. Observe minimum installation clearances (Fig. 3, page 12). 4. Clean burner (see CARE AND MAINTENANCE, pages 25 & 26) or contact customer service.

### **QUALIFIED INSTALLING AGENCY**

Only a qualified agency should perform installation and replacement of gas piping, gas utilization equipment or accessories, and repair and servicing of equipment. The term “qualified agency” means any individual, firm, corporation, or company that either in person or through a representative is engaged in and is responsible for the following:

- A. Installing, testing, or replacing gas piping; or
- B. Connecting, installing, testing, repairing, or servicing equipment and is a.) experienced in such work, b.) familiar with all precautions required, and c.) has complied with all the requirements of the authority having jurisdiction.

### **Customer Service**

If you did not find the solution to your problem or have a product question, contact our customer service at: 1-888-534-1578 or support@hhdyn.com

## Parts List

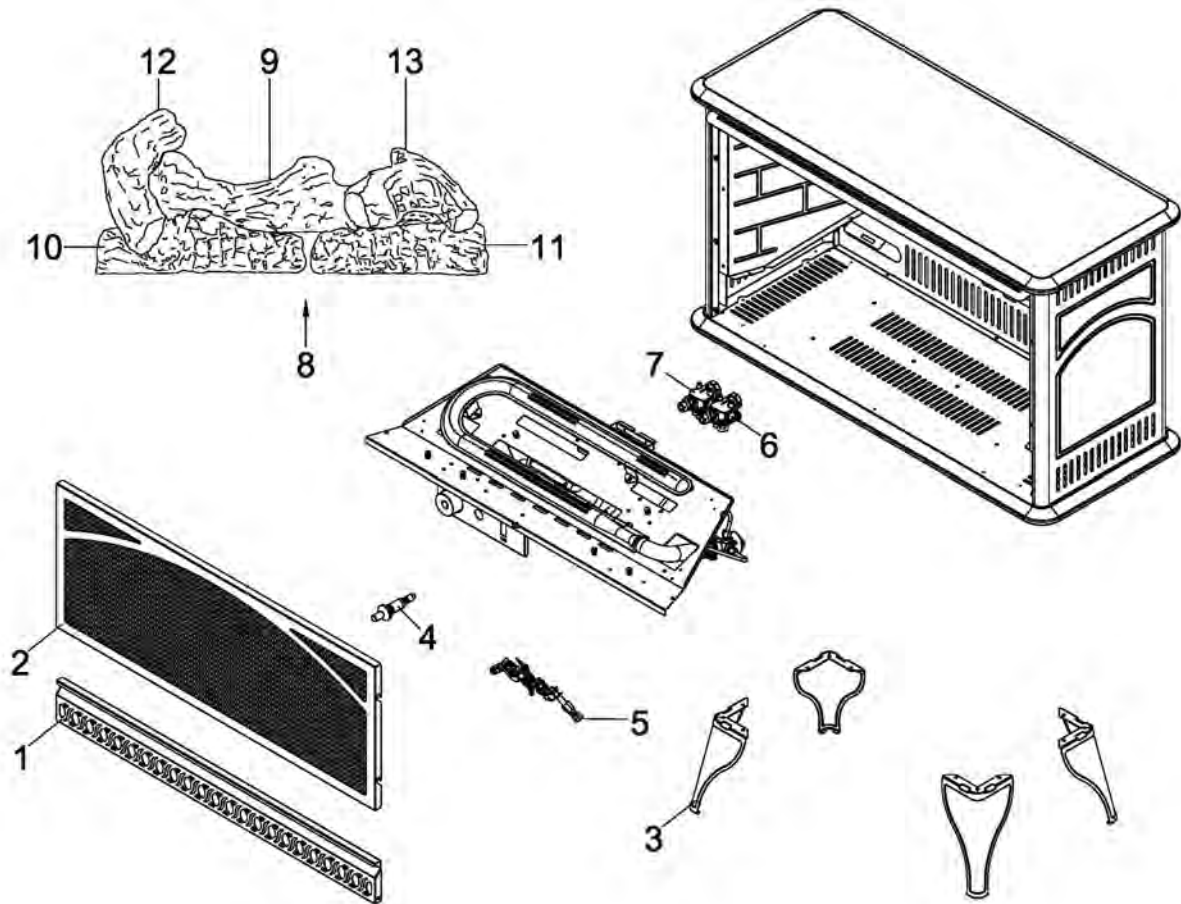

ITEM No.	DESCRIPTION	QTY	ARSTDF26I
1	Louver	1	VFS25-007HZ
2	Screen	1	VFS25-008HZ
3	Support Legs	4	VFS25-014
4	Piezo	1	YQ610-2A2/B16
5	Dual Fuel ODS	1	Bn3503e
6	Regulator LPG	1	7011H-9
7	Regulator NG	1	7011L-4-30
8	Log Set (Complete)	1	VFS25-300B
9	Log 1	1	VFS25-301
10	Log 2	1	VFS25-302
11	Log 3	1	VFS25-303
12	Log 4	1	VFS25-304
13	Log 5	1	VFS25-305

For replacement parts, contact 1-888-534-1578.

## **WARRANTY**

### **KEEP THIS WARRANTY**

Always specify model and serial numbers when communicating with customer service.

We reserve the right to amend these specifications at any time without notice. The only warranty applicable is our standard written warranty. We make no other warranty, expressed or implied.

### **LIMITED WARRANTY**

### **VENT-FREE GAS SPACE HEATERS**

This product is warranted to be free from defects in materials and components and limited labor for (3) THREE years from the date of first purchase, provided that the product has been properly installed, operated and maintained in accordance with all applicable instructions. To make a claim under this warranty, the Bill of Sale or cancelled check must be presented.

This warranty is extended only to the original retail purchaser. This warranty covers the cost of part(s) required to restore this heater to proper operating condition and an allowance for labor when provided. Warranty part(s) MUST be obtained through authorized dealers of this product, who will provide original factory replacement parts. Failure to use original factory replacement parts voids this warranty. The heater MUST be installed by a qualified installer in accordance with all local codes and instructions furnished with the unit.

This warranty does not apply to parts that are not in original condition because of normal wear and tear or parts that fail or become damaged as a result of misuse, accidents, lack of proper maintenance or defects caused by improper installation.

Some states do not allow limitation on how long an implied warranty lasts or an exclusion or limitation of incidental or consequential damages, so the above limitation on implied warranties, or exclusion or limitation on damages may not apply to you.

Always be sure to specify the model number and serial number when making any claim. For your convenience, use the space provided below to list this information.

#### Locating Your Serial Number:

Your serial number can be found on the tags on the back or side of your appliance. It will be up to thirteen characters (for example: FAN2012345678). Have your serial number ready before calling customer service at 1-888-534-1578.

Model #: \_\_\_\_\_

Serial #: \_\_\_\_\_

Date of Purchase: \_\_\_\_\_



Printed in China

ALLEN + ROTH and logo design are  
trademarks or registered trademark of LF, LLC.  
All rights reserved.